

ODB7530 Series

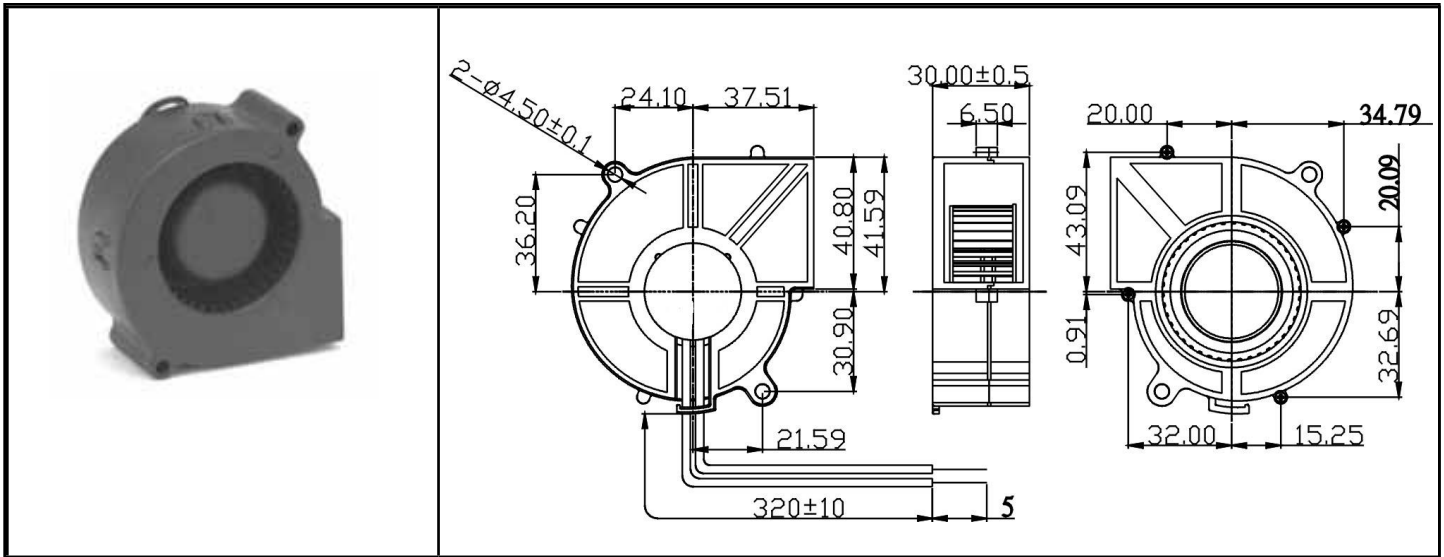

DC side inlet blower
75x30mm (2.95"x 1.18")



Frame	PBT, UL94V-0	Notes
Impeller	PBT, UL94V-0	Date: 071615
Connection	Lead wires*	<u>Available Options</u>
Motor	Brushless DC, IC protected	Tachometer Alarm Thermal Control
Bearing System	Dual ball bearing	
Insulation Resistance	10M ohm between lead wire and frame (500VDC)	* Connections UL1007, AWG24, ~320mm Red (+) Black (-)
Dielectric Strength	60 second at 500VAC, max. leakage < 500 MicroAmp	
Temperature Range	-10C ~ +70C	
Life Expectancy	70000 hours (40C L10)	

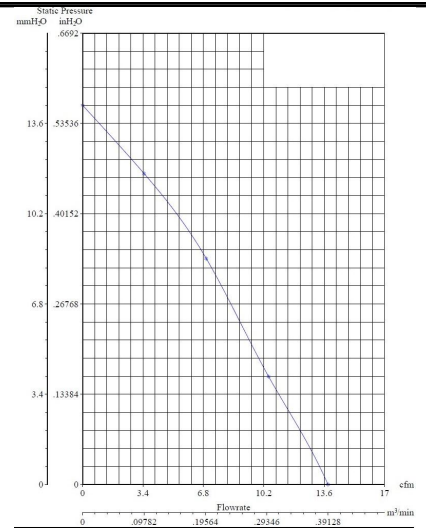

Model Number	ODB7530-12HB	ODB7530-24HB
Part Number	103141001	103241001
Nominal Voltage	12 VDC	24 VDC
Voltage Range	7 ~ 13.2 VDC	17 ~ 26.4 VDC
Rated Current	0.36 A (+10% max)	0.20 A (+10% max)
Input Power	4.32 W	4.80 W
Rated Speed (RPM)	3400	3400
Airflow (CFM)	13.8	13.8
Noise Level (dB)	41.7	41.7
Max. Static Pressure (" H ₂ O)	0.56	0.56