

OD6020 Series

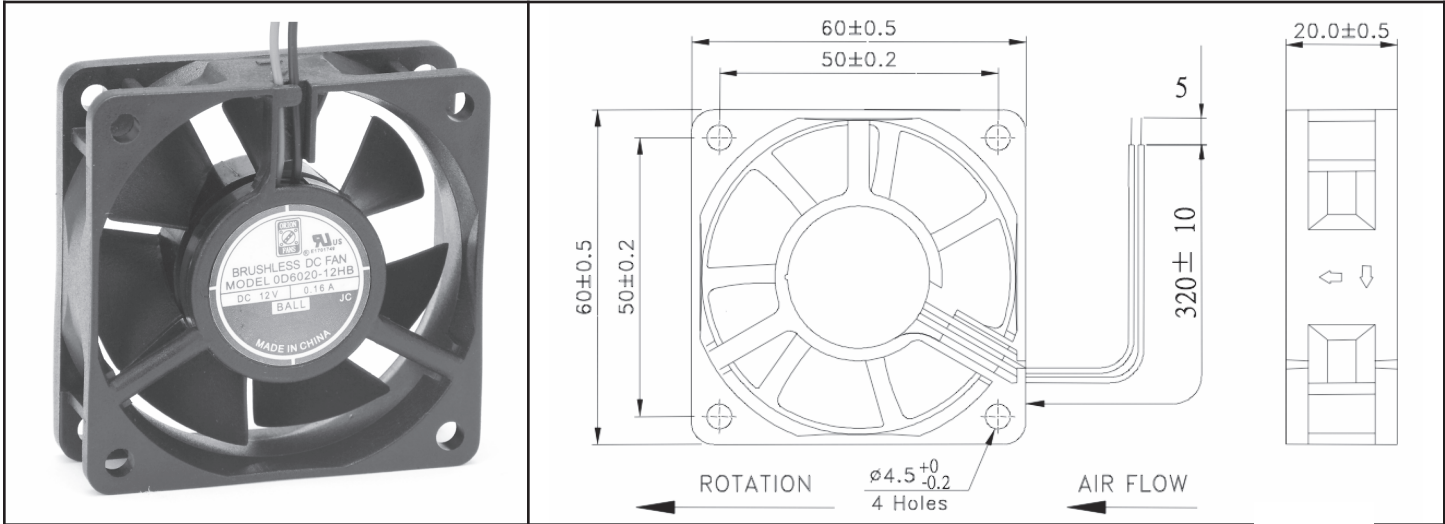

DC Fan - 12, 24V
60x20mm (2.36"x .79")



Frame & Impeller	PBT, UL94V-0 plastic	Available Options: Tachometer Alarm Other frame styles available 5V available on request <u>Life Expectancy (L10)</u> Ball Bearing 60,000 hours (L10 at 40C) Sleeve Bearing 30,000 hours (L10 at 40C) <u>Operating Temperature</u> Ball Bearing -10C ~ 70C Sleeve Bearing -10C ~ +50C Weight: ~ 0.11 lbs m1	
Connection	2x Lead wires		
Motor	Brushless DC, auto restart, polarity protected		
Bearing System	Dual Ball or Sleeve		
Insulation Resistance	10M ohm between leadwire and frame (500VDC)		
Dielectric Strength	1 minute at 500 VAC, max leakage < 500 MicroAmp		
Storage Temperature	-40C ~ +80C		

Model Number	Speed (RPM)	Airflow (CFM)	Noise (dB)	Volts DC	Voltage Range	Amps	Max. Static Pressure (\"H ₂ O)
OD6020-12H*	4500	18	30	12	10.8~13.2	0.16	0.14
OD6020-12M*	3900	15	26	12	10.8~13.2	0.13	0.11
OD6020-12L*	3500	13	22	12	10.8~13.2	0.08	0.09
OD6020-24H*	4500	18	30	24	21.6~26.4	0.09	0.14
OD6020-24M*	3900	15	26	24	21.6~26.4	0.06	0.11
OD6020-24L*	3500	13	22	24	21.6~26.4	0.04	0.09

* Indicate "B" to specify Ball bearing or "S" to specify Sleeve bearing